

# **Module 11: Conducted Emissions**

## 11.1 Overview

The term conducted emissions refers to the mechanism that enables electromagnetic energy to be created in an electronic device and coupled to its AC power cord. Similarly to radiated emissions, the allowable conducted emissions from electronic devices are controlled by regulatory agencies. If a product passes all radiated emissions regulations but fails a conducted emissions test, the product cannot be legally sold.

The primary reason that conducted emissions are regulated is that electromagnetic energy that is coupled to a product's power cord can find its way to the entire power distribution network that the product is connected to and use the larger network to radiate more efficiently than the product could by itself. Other electronic devices can then receive the electromagnetic interference through a radiated path (or, much less frequently, a direct electrical connection). The frequency range where conducted emissions are regulated is typically lower than the frequency range where radiated emissions are regulated. The longer wavelengths where conducted emissions are a problem need a much larger antenna to radiate and receive electromagnetic interference than the shorter wavelengths studied for radiated emissions.

This module will investigate conducted emissions by studying its sources and methods to its reduction techniques. First the Line Impedance Stabilization Network (LISN) will be studied to give an overview on how conducted emissions are measured. A review of common and differential mode currents will then be given with a perspective on their importance to conducted emissions. The most important mitigation tool for conducted emissions, power supply filters, will then be covered. Next, power supplies themselves will be studied, which are the most frequent source of conducted emissions. Finally, a short section on conducted immunity will be given. Conducted immunity refers to a product's resilience to electromagnetic interference coupled in through its AC power cord.

## 11.2 The Line Impedance Stabilization Network (LISN)

As an engineer in the EMC field, it is important to understand the measurement procedures that are used to measure conducted emissions. Conducted emissions are regulated by the FCC over the frequency range 450 kHz to 30 MHz, and the CISPR 22 conducted emissions limits extend from 150 kHz to 30 MHz. When testing a device for compliance with the FCC and CISPR 22 regulatory limits, a line impedance stabilization network (LISN) must be inserted between the ac power cord of the device under test and the commercial power outlet. Due to the difference in regulated frequency ranges between the FCC and CISPR 22 regulations, the LISNs for the two have similar layouts but the component values are different. Below is a diagram of the test setup used to test compliance with conducted emissions limits.

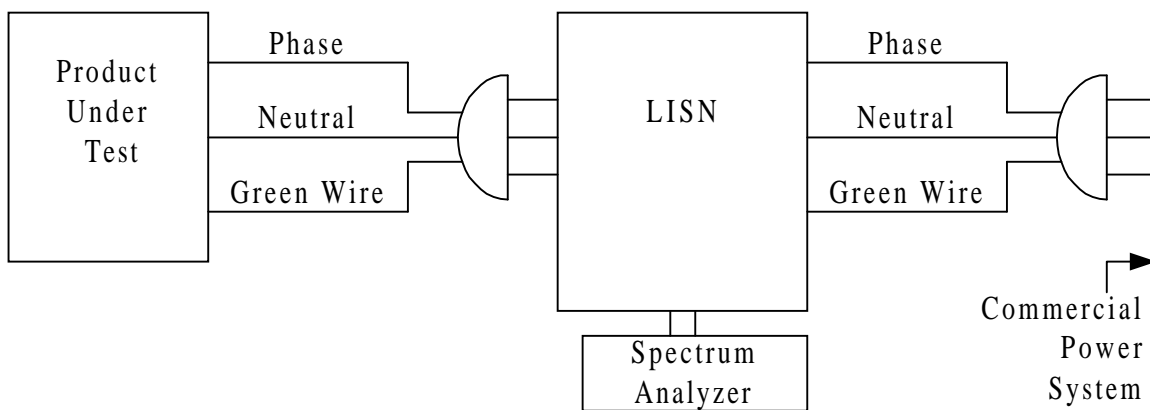

As shown in the diagram, the ac power cord of the product under test is plugged into the input of the LISN, and the output of the LISN is plugged into the commercial power system outlet. AC power is filtered through the LISN and the product is provided with “unpolluted” ac power. A spectrum analyzer is connected to the LISN and measures the conducted emissions from the product under test.

The purpose of conducted emissions testing is to measure noise currents that exit the product under test’s ac power cord and make sure these currents are within the regulated limits. FCC and CISPR 22 regulations require that measured data be correlatable between measurement facilities. Since the currents exiting the device under test are dependant on the load on the ac power cord, and this load is the impedance seen by the device looking into the ac power outlet, which varies considerably over the measurement frequency range from outlet to outlet and from building to building, it is not sufficient to measure the noise currents on the power cord with a current probe. Instead, the product under test is connected to a LISN, which stabilizes the impedance seen by the product looking out the ac power cord. This is the first of the two objectives of the LISN. The second objective of the LISN is to block external noise that exists on the power system net from entering the product’s ac power cord. Any noise currents from the power system net that were to enter the product’ ac power cord would add to the conducted emissions from the device. Since we are only interested in the conducted emissions that emanate from the device under test, it is

important that the LISN prevent noise from the power system net from entering the product's ac power cord. The LISN must satisfy both of these objectives over the entire conducted emissions frequency range (450 kHz-30 MHz for FCC regulations and 150 kHz-30 MHz for CISPR 22 regulations), yet still allow the 60 Hz power to reach the device under test.

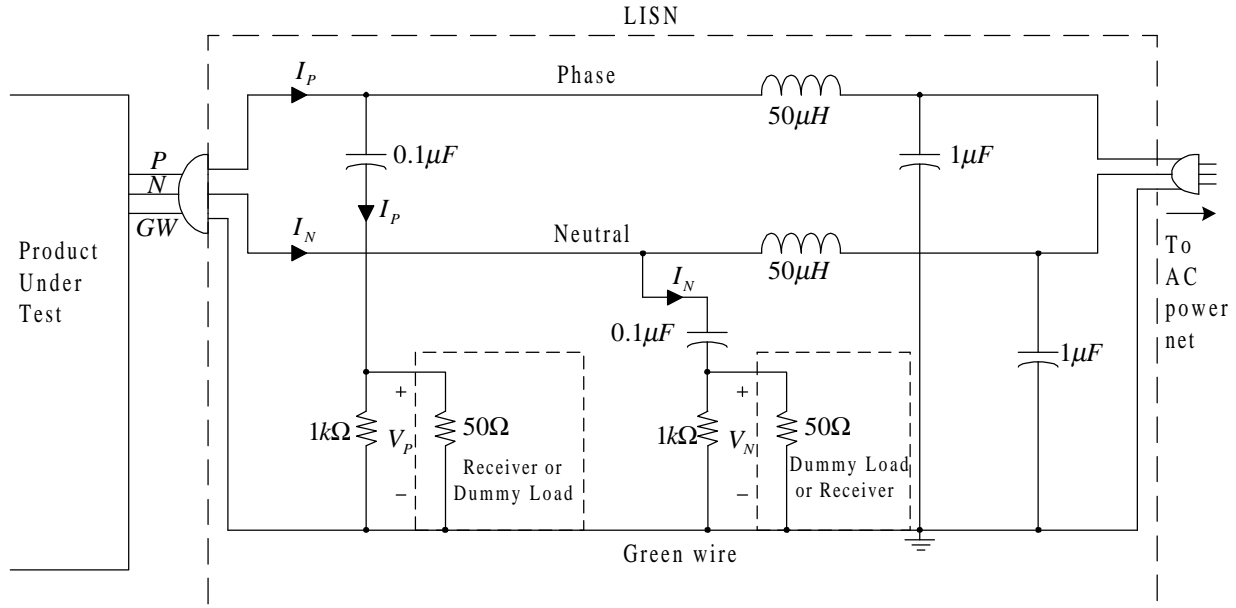

Above is a diagram showing the layout for the LISN specified for use in the FCC conducted emissions measurements. The 50  $\mu\text{H}$  inductors block external noise on the commercial power net from flowing through the measurement device and contaminating the test data, while the 1  $\mu\text{F}$  capacitors provide an alternate path for those noise currents and divert them from the measurement device. The other 0.1  $\mu\text{F}$  capacitors prevent any dc from overloading the input of the test receiver. The 1  $\text{k}\Omega$  resistors act as static charge paths to discharge the 0.1  $\mu\text{F}$  capacitors in the event that the 50  $\Omega$  resistors are removed. One of the 50  $\Omega$  resistors is the input impedance of the spectrum analyzer, while the other is a dummy load that insures that the impedances between the Phase and Green wire and between the Neutral and Green Wire are approximately 50  $\Omega$  at all times.

It is helpful to understand the function of the LISN if we compute the impedances of the inductors and capacitors at the upper, 30 MHz, and lower, 450 kHz, frequency ranges of the FCC regulatory limits, as well as the normal power frequency, 60Hz.

Element	$Z_{450\text{kHz}}$	$Z_{30\text{MHz}}$	$Z_{60\text{Hz}}$
50 $\mu\text{H}$	141.3 $\Omega$	9420 $\Omega$	0.0188 $\Omega$
0.1 $\mu\text{F}$	3.54 $\Omega$	0.053 $\Omega$	26500 $\Omega$

1 $\mu$ F	0.354 $\Omega$	0.0053 $\Omega$	2650 $\Omega$
-----------	----------------	-----------------	---------------

Thus, at the testing frequencies, the capacitors are essentially short circuits, and the inductors provide large impedances. If we approximate these large impedances as open circuits, the LISN equivalent circuit at the conducted emissions test frequencies becomes

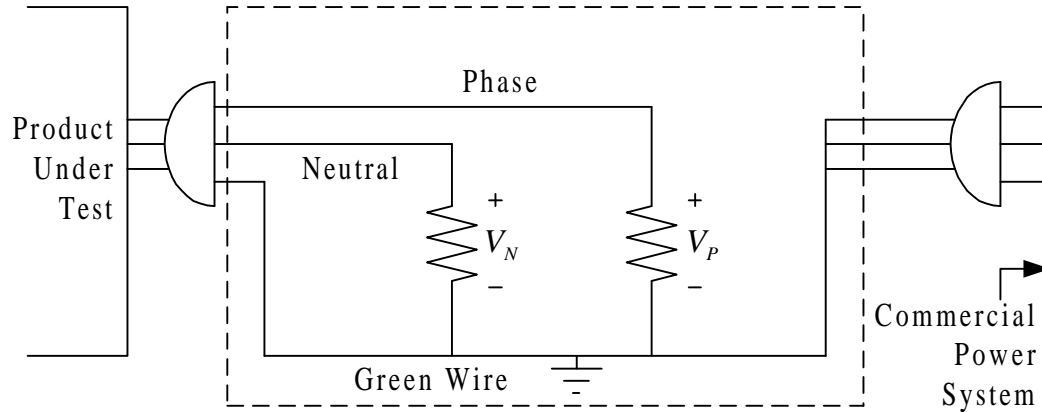

The measured voltage  $V_P$  is measured between the Phase and Green Wires, and the measured voltage  $V_N$  is measured between the Neutral and Green Wires. Both, the Phase and Neutral voltages must be measured over the entire frequency range defined for conducted emissions, and both must be below the specified limits at all frequencies within that frequency range. Although the quantities being regulated are the Phase and Neutral voltages, it is easy to see that the conducted emissions limits truly limit the conducted emissions currents, since the impedances that the voltages are across are regulated to be 50  $\Omega$ .

$$I_P = \frac{1}{50} V_P$$

$$I_N = \frac{1}{50} V_N$$

The LISN should not affect the operation of the product under test at the 60 Hz power frequency. If we construct an equivalent circuit for the LISN using the impedance values we computed in the earlier table, we can approximate the capacitors as open circuits and the inductors as short circuits. The equivalent circuit at the power frequency becomes

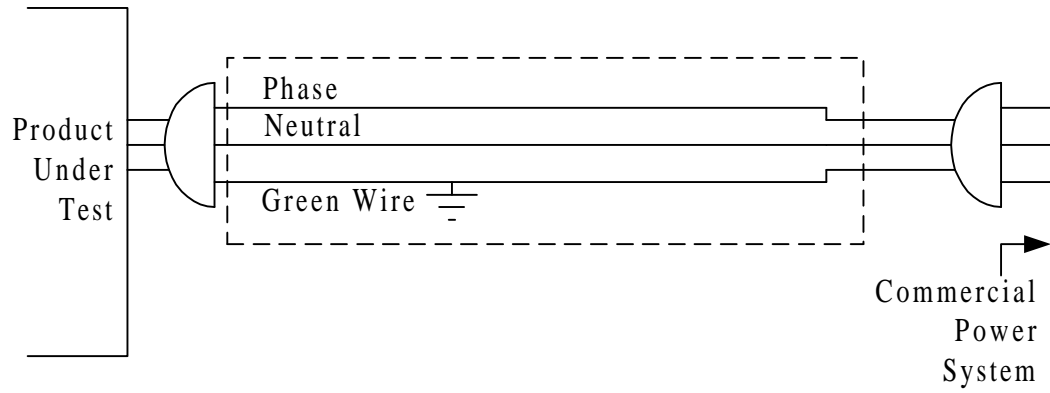

This demonstrates that at the 60 Hz power frequency the LISN has virtually no effect on the product under test and ac power is provided for functional operation of the device.

## 11.3 Common and Differential Mode Currents

As discussed in the previous section, the purpose of the LISN is to provide standard impedances for the phase and neutral wires of a device so that the conducted emissions can be measured by measuring the voltages across these impedances. A diagram of the conducted emissions testing setup is shown in **Figure 1**. In this figure, the circuitry of the LISN has been replaced by two  $50\ \Omega$  loads which represent the LISN at the frequencies where conducted emissions are measured. From the figure:

$$I_P = I_C + I_D$$

$$I_N = I_C - I_D$$

or

$$I_C = \frac{1}{2}(I_P + I_N)$$

$$I_D = \frac{1}{2}(I_P - I_N).$$

Assuming that the  $50\ \Omega$  impedances are constant across the frequency band that is to be measured, the voltages across the impedances are

$$V_P = 50\ \Omega \cdot (I_C + I_D)$$

and

$$V_N = 50\ \Omega \cdot (I_C - I_D).$$

Thus by measuring the voltages across the impedances by using a spectrum analyzer, the common and differential mode currents can be found by:

$$I_C = \frac{1}{2} \frac{(V_P + V_N)}{50\ \Omega}$$

$$I_D = \frac{1}{2} \frac{(V_P - V_N)}{50\ \Omega}.$$

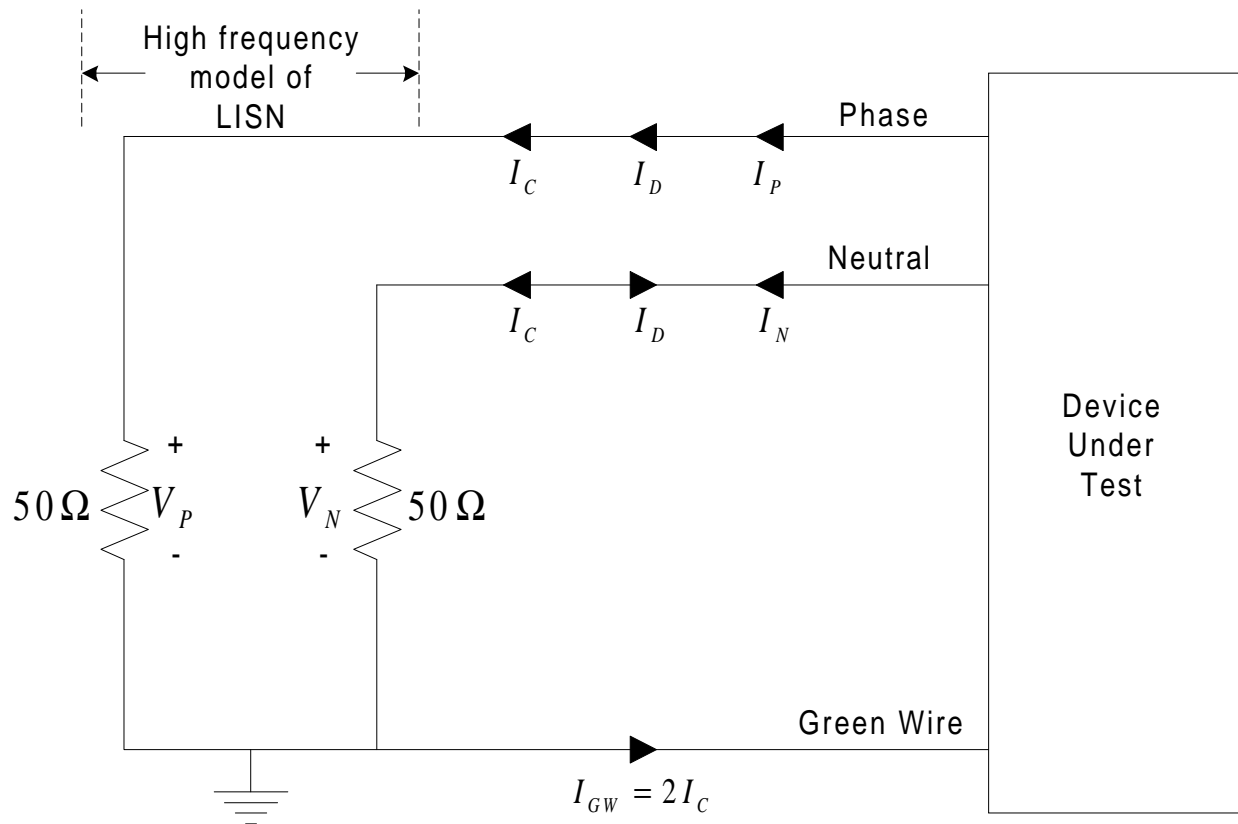

**Figure 5:** Diagram of common and differential mode currents on a product's AC power cord.

It can be seen from the above equations that if the common mode and differential mode currents are approximately equal, then  $V_P$  and  $V_N$  will be very different. However, if either the common mode current dominates the differential mode current, then  $V_P$  and  $V_N$  will be approximately equal. Likewise, if the differential mode current dominates the common mode current, then  $V_P$  will be approximately equal to  $V_N$  in magnitude but opposite in phase.

The common mode current that exists by returning on the green wire is unintended and usually is not part of the design of the product. It is important to remember that the green wire exists to provide a path for current at 60 Hz in the event of a ground fault so that the circuit breaker or the fuse of the AC power can be blown. It is not intended to carry 60 Hz current under normal operational circumstances. However, at the higher frequencies where conducted emissions are measured, the green wire can carry common mode current that can cause a product to fail regulatory standards.

There are two primary methods of suppressing the high frequency common mode current returning on the green wire. The first method is to simply wind the green wire around a ferrite core after the green wire has entered the product casing and before the wire is soldered to the case. This creates an inductance in that can help reduce the common mode current emissions. The ferrite core should be chosen such that it has a high permeability over the conducted



emissions frequency band. The inductor should not interfere with the purpose of the green wire, which is to provide a path for the 60 Hz current to prevent a possible shock hazard.

The second method used to block the common mode current is to completely remove the green wire and create a two wire device. Right at the power cord input to the product, a transformer is used to electrically isolate the product from the phase and neutral wires to reduce the risk of a shock hazard. The chassis is then often tied to the secondary side of the transformer. This method can help reduce the measured common mode conducted emissions current, but a path for common mode current may still exist. The return path for possible common mode current can be capacitive coupling between the metallic chassis of the product and the ground of the measurement site.

In the next section, we will discuss the most important tool used to reduce the conducted emissions of a product. The power supply filter can help greatly reduce the differential mode conducted emission of a product. However, most filters are not designed to reduce common mode conducted emissions.

## 11.4 Power supply filters

Virtually no electronic products today can comply with conducted emissions regulations without the aid of a power supply filter. Power supply filters are inserted where the power cord exits a device, thus they prevent conducted emissions currents from exiting the device.

Electric filters are used in many electrical engineering applications, and design information is easily attainable for a variety of electric filters. However, due to the high frequency range of conducted emissions testing, and the fact that both common and differential mode currents must be reduced, traditional electric filters are not sufficient to reduce conducted emissions. Instead, power supply filters are designed to reduce both common and differential mode currents across the entire conducted emissions frequency spectrum.

Despite the fact that power supply filters are designed differently than traditional electric filters, they still exhibit common filter characteristics. With this in mind, it is important to discuss some basic properties of filters. Filters are typically characterized by their insertion loss (IL), which is expressed in dB. The insertion loss is a measure of the load reduction at the given frequency due to the insertion of the filter. It is very important to note that the insertion loss of a filter is dependant on the source and load impedances, and thus cannot be stated independently of the terminal impedances. Despite this fact, filter manufacturers often list an insertion loss value on a filter's data sheet without specifying the terminal impedance values. When this occurs, the source and load impedances are assumed to both equal 50  $\Omega$ . This is very misleading, because even though the load impedance will remain 50  $\Omega$  as it is the impedance regulated by the LISN, the source impedance is dependant on the device the filter is hooked up to. Thus, for that particular filter to work properly with your device, the input impedance seen looking into the power cord of your device must be 50  $\Omega$  at all frequencies in the conducted emissions range. Since this is a rather unrealistic design constraint to place on a product, it is unlikely that the use of such a filter on your product will result in the filtering results specified by the manufacturer's insertion loss data. Because of this, it may be desirable for manufacturer's to develop their own filters for their products, rather than applying pre-manufactured filters.

An important aspect of power supply filters is the fact that they must reduce both the common and differential mode currents from the device they are filtering in order to satisfy conducted emissions regulations. Since differential mode current, by definition, flows out the Phase wire and returns via the Neutral wire, no differential mode current will flow on the Green Wire. Thus, to determine the differential mode insertion loss, the product should be connected to the Phase and Neutral wires, but not the Green Wire, as shown here.

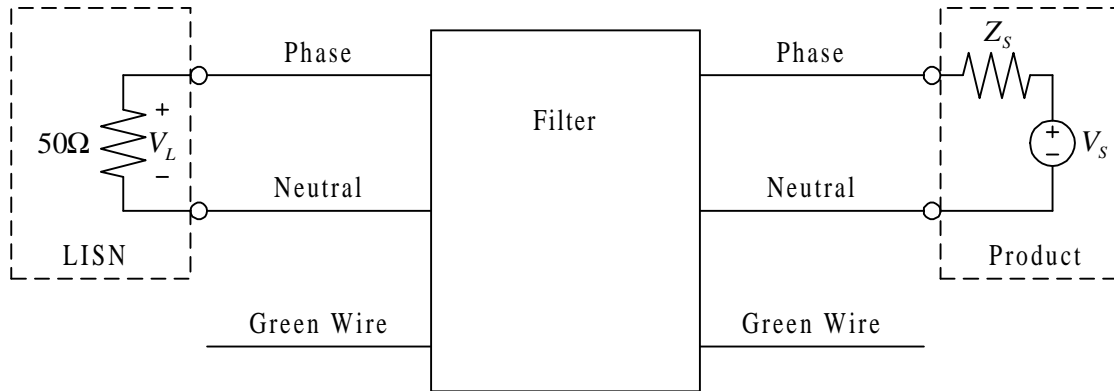

To measure the common mode insertion loss the Phase and Neutral wires should be tied together and the Green Wire is connected to the circuit. The test circuit will look like this.

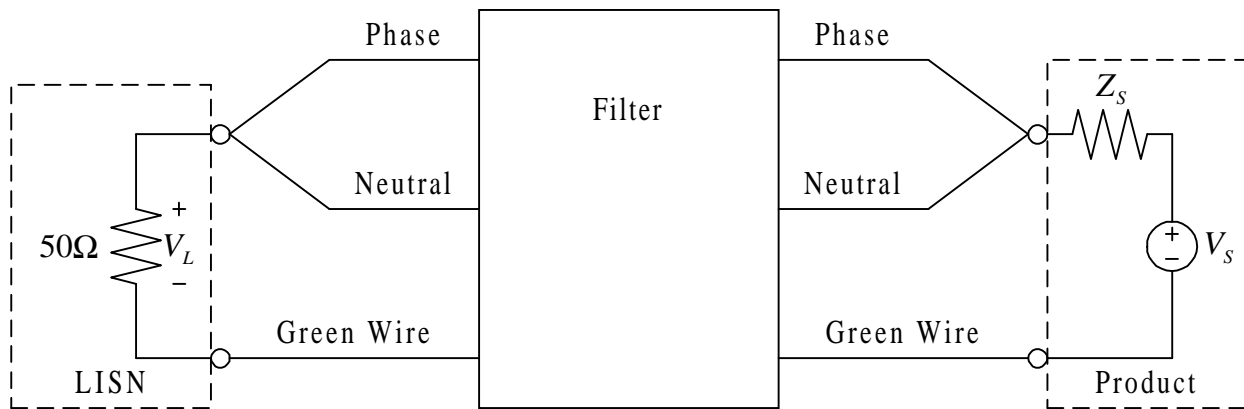

In both cases,  $Z_s$  is the impedance seen looking into the power cord of the product. For commercially made filters the data sheet insertion loss values are based on  $Z_s = 50 \Omega$ . The actual insertion loss values for a filter being used on a product can be determined using these test set-ups.

The layout for a common power supply filter is shown here.

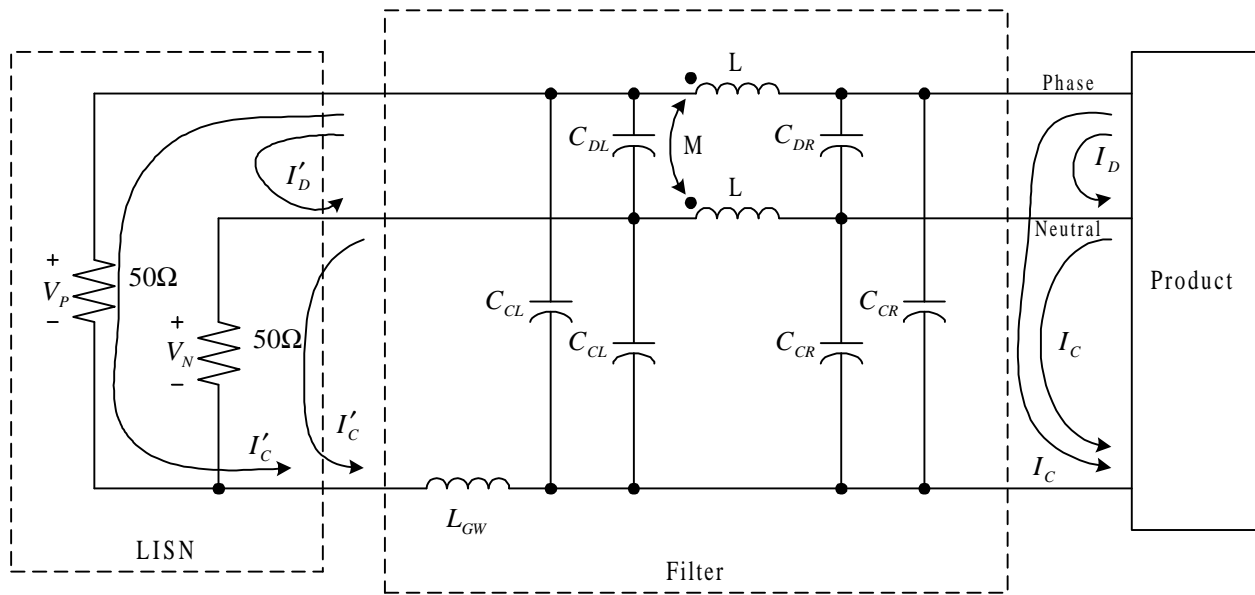

The common and differential mode currents  $I_C$  and  $I_D$  exit the product and enter the filter. The filter then takes these input currents and outputs common and differential mode currents  $I'_C$  and  $I'_D$ , which are then measured by the LISN. The object of the filter is to reduce  $I_C$  and  $I_D$  to the current levels  $I'_C$  and  $I'_D$  such that the voltages that the LISN measures are

$$V_p = 50(I'_C + I'_D)$$

$$V_n = 50(I'_C - I'_D)$$

and that these voltages are below the conducted emissions limits at all regulated frequencies.

Now that we understand the objective of the power supply filter, it is important that we understand how the filter works. With this knowledge we will be able to modify the general filter so that it will reduce the conducted emissions of the product to acceptable levels. As discussed earlier, the Green Wire inductor  $L_{GW}$  is included in the Green Wire between the filter output and the LISN input, and it blocks common mode currents. The capacitors between Phase and Ground wires,  $C_{DL}$  and  $C_{DR}$ , where the subscripts L and R denote left and right with respect to the side of the filter on which they are placed, are included to divert differential mode currents. These capacitors are referred to as line-to-line capacitors and have typical values around  $C_D = 0.047 \mu\text{F}$ . Capacitors that have insulator properties approved by safety agencies and are suitable for use as line-to-line capacitors are referred to as “X-caps.” The capacitors,  $C_{CL}$  and  $C_{CR}$  are called line-to-ground capacitors, and they divert common mode current. They are placed between Phase and Green Wire and between Neutral and Green Wire. A typical value for line-to-ground capacitors is  $C_C = 2200 \text{ pF}$ . Capacitors that have insulator properties approved by safety agencies and are suitable for use as line-to-ground capacitors are referred to as “Y-caps.” Multiple Y-caps are required in power supply filters for safety reasons. To illustrate why multiple Y-caps are necessary, consider a case where there is only one Y-cap connected between the Phase and Green

Wire. If that Y-cap happened to short out 120 V would now be tied to the Green Wire. Since the Green Wire is often tied directly to the frame of the product, having only one Y-cap could cause a serious shock hazard. Aside from requiring multiple Y-caps in a filter, safety agencies such as the Underwriters Laboratory in the US also specify a maximum leakage current that may flow through each line-to-ground capacitor at 60 Hz. The maximum leakage current is regulated so that each capacitor may carry a maximum of one half of the total. Notice that the line-to-ground capacitors on the left,  $C_{CL}$ , are in parallel with the  $50\ \Omega$  resistors of the LISN. Therefore, if the impedances of these capacitors are not significantly lower than  $50\ \Omega$  in the frequency range of conducted emissions, then they will be ineffective in diverting the common mode currents. For example, if the left line-to-ground capacitors are typical values,  $C_{CL} = 2200\text{pF}$ , then the impedance of the capacitors will be  $50\ \Omega$  at 1.45 MHz. Thus, the capacitors,  $C_{CL}$ , will only be effective in diverting common mode currents at frequencies over 1.45 MHz.

The final component in the typical power supply filter is the common mode choke, which is represented by the coupled inductors in the figure. The coupled inductors have self inductances, represented by  $L$ , and mutual inductance,  $M$ . This element consists of two identical windings on a common ferrite core, much like a transformer.

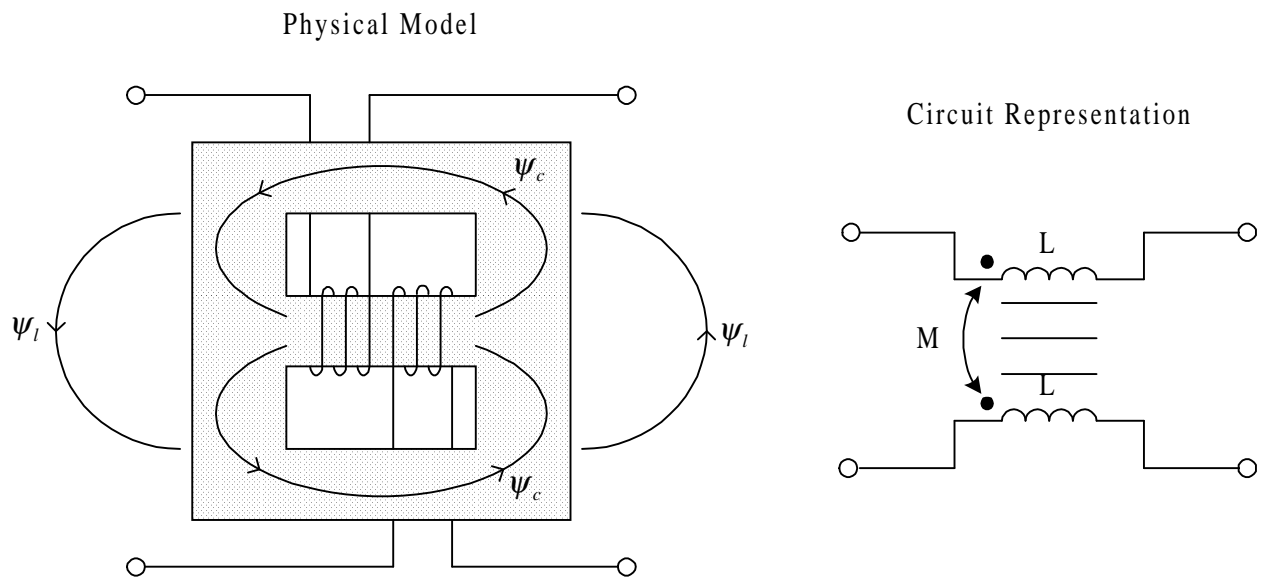

Since the windings are identical and are wound tightly on the same core, the mutual inductance is approximately equal to the self inductance, thus the coupling coefficient of the choke approaches unity.

$$k = \frac{M}{\sqrt{L_1 L_2}} \approx \frac{M}{L} \approx 1 \quad \dots L_1 \approx L_2$$

The purpose of the common mode choke is to block common mode currents without affecting the

differential mode currents. It is useful to illustrate the operation of the common mode choke by examining it separately for common and differential mode currents. If we consider the choke with only differential mode currents we can compute the voltage drop across one side of the choke.

$$V = j\omega LI_D - j\omega MI_D$$

$$= j\omega(L - M)I_D$$

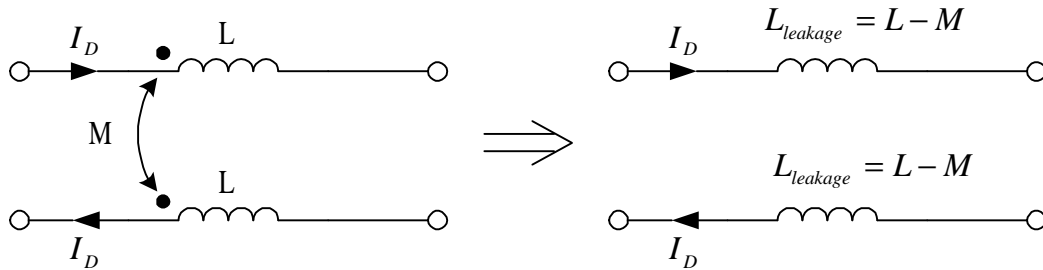

Thus, with regard to differential mode currents, the common mode choke inserts an inductance  $L - M$  in each lead. This inductance is referred to as the leakage inductance and is due to a portion of the magnetic flux that leaks out the core and does not couple between the windings. Ideally, since  $L \approx M$ , the leakage inductance is zero and the common mode choke has no effect on differential mode currents. In practice, however, the leakage inductance is small but non-zero.

If we now consider the effect of the common mode choke on common mode currents, we can compute the voltage across one side of the choke.

$$V = j\omega LI_C + j\omega MI_C$$

$$= j\omega(L + M)I_C$$

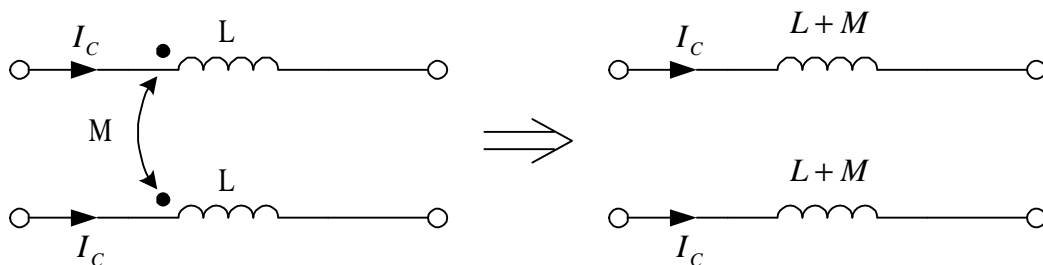

Thus, the common mode choke inserts an inductance  $L + M$  in each lead with regard to common mode currents. As a result, the common mode choke will block common mode currents. This is apparent if we consider typical values of the inductance, which are on the order of 10 mH. Thus, the common mode current impedance is  $j\omega(L + M) = 56,549 \Omega$  at 450 kHz and  $3.77 \text{ M}\Omega$  at 30 MHz. It is important to note that these are ideal values and variables such as parasitic capacitance between the windings and the type of core material could affect the frequency behavior of the choke.

Now that we have established the behavior of the various components, it is valuable to develop equivalent circuits for the filter for both common and differential mode currents. We will simulate

the common mode currents as current sources. For common mode currents, the power supply filter circuit looks like this.

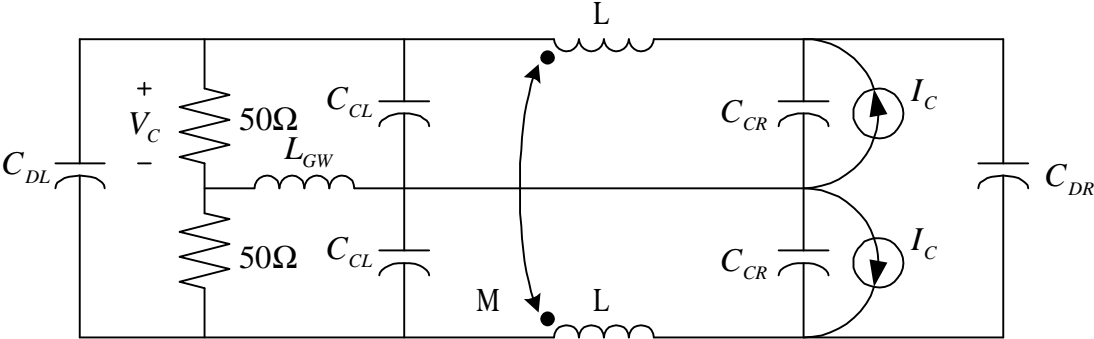

By writing mesh equations this circuit simplifies to the equivalent circuit for the filter and LISN for common mode currents.

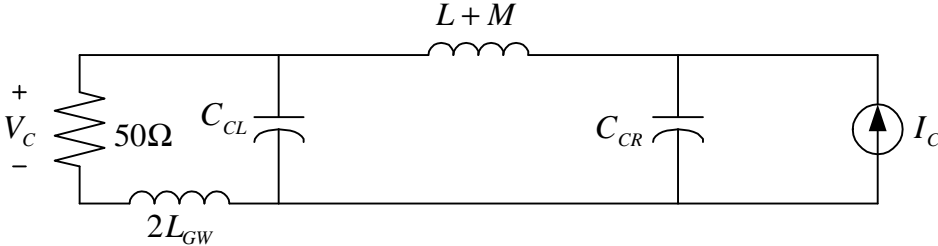

For the differential mode circuit, we will again simulate the differential mode currents as current sources. The circuit looks like this.

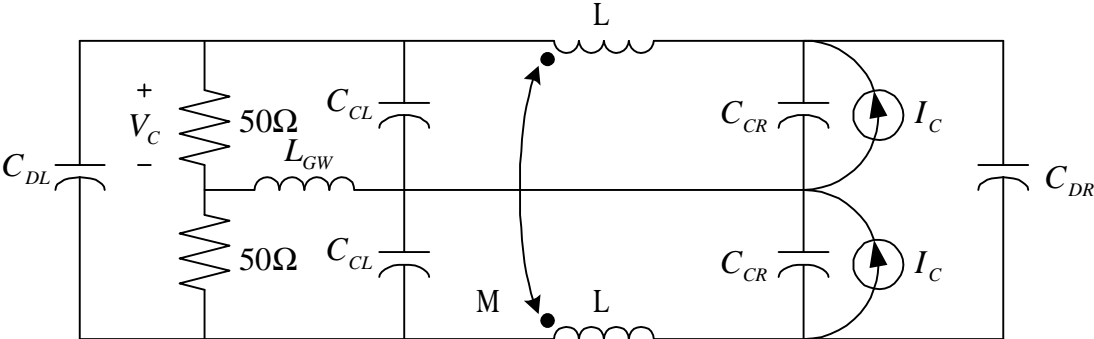

Again, we can reduce this circuit to a simpler equivalent circuit by using mesh equations. The

equivalent circuit of the filter and LISN for differential mode currents looks like this.

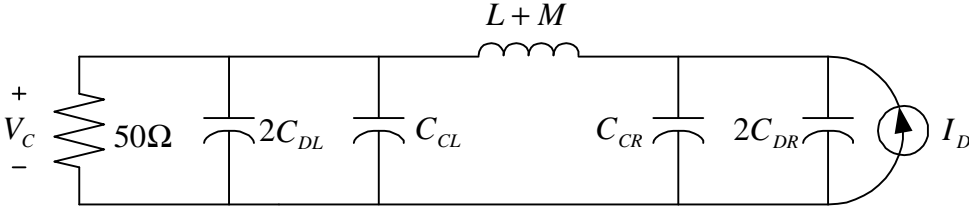



## 11.5 Power Supplies

One of the largest sources of conducted emissions for typical products is their power supply. Most of the internal electronics for products under regulations rely on DC sources for power. A direct current source is created using a power supply that converts the AC line voltage to a DC voltage. In the process of doing so, many power supplies create unwanted high frequency signals that may not interfere with the functional operation of the product, but may couple back on to the product's AC power cord. This unwanted EM energy is then measured as conducted emissions from the product, possibly causing the product to fail in a regulatory test.

This section will discuss the two primary types of power supplies and their roles in generating conducted emissions for the products that they are used in. First, linear power supplies will be discussed, which are typically the cleanest AC to DC power supplies but are inefficient and bulky. Second, switched mode power supplies will be discussed, which typically generate a lot of unwanted RF energy but are lighter in weight and smaller than linear power supplies.

### 11.5.1 Linear Power Supplies

The type of power supply used most commonly in the past for converting 120 volts AC to DC voltage was the linear power supply. A simplified diagram of a linear power supply is shown in **Figure 2**. The transformer is in place to step the input AC voltage up or down (usually down) to a desired amplitude before rectification and to provide some filtering, which will be discussed later. The rectifier section converts the 60 Hz AC waveform to a pulsating DC waveform, as shown in **Figure 3**. The capacitor  $C_1$  is in used to try to smooth out the pulsating DC waveform.

The regulation section is extremely important when loads draw power from the linear power supply. As current is drawn from the supply, the output DC voltage wants to drop below its designed value. However, by feeding back some of the output  $V_{out}$  to the base of the transistor, the voltage across the transistor's collector and emitter is reduced as  $V_{out}$  drops. Thus the regulator helps supply a constant DC output voltage for the power supply under typical loading conditions.

After the regulator section of the power supply comes a filtering section. The filter shown in the diagram is a simple pi filter constructed using two capacitors (both equal to  $C_2$ ) and one inductor ( $L$ ). This filtering section reduces the "ripple" left by the rectifier and regulator sections of the power supply.

The linear power supply is a reasonably clean power supply when dealing with conducted emissions. The transformer core is designed to operate at the commercial power frequency (60 Hz), but is very inefficient at the higher frequencies where conducted emissions are measured.

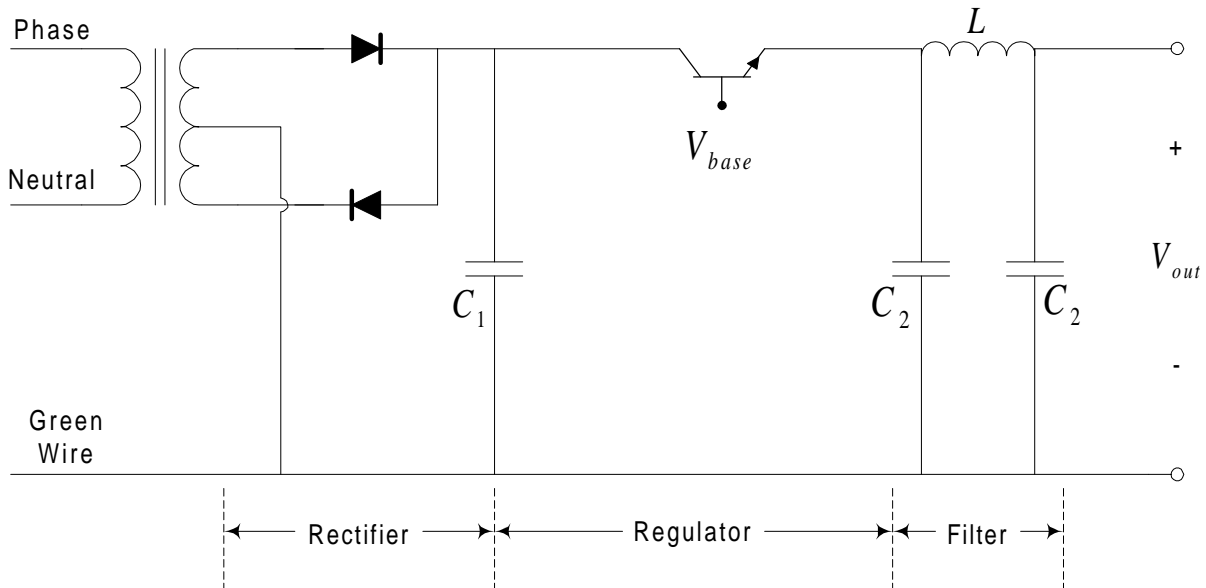
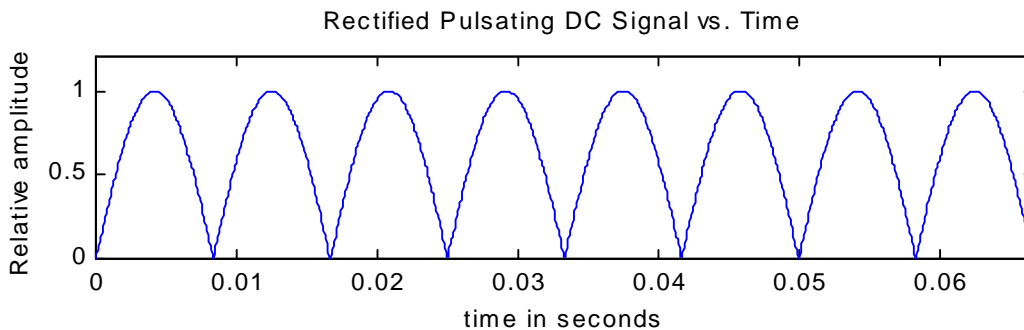
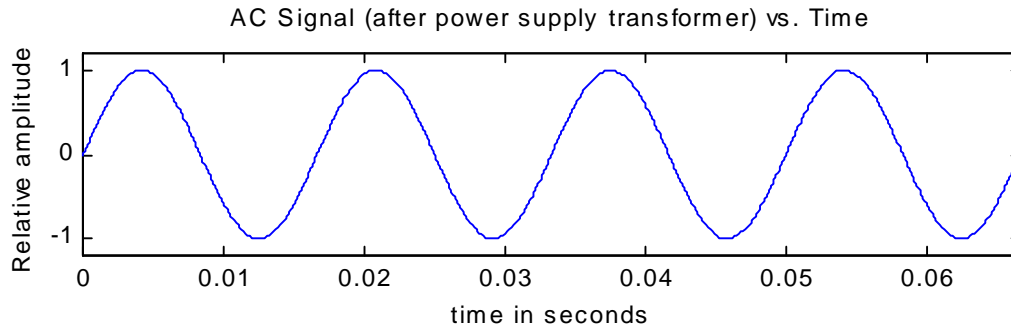

**Figure 16: Linear Power Supply**

Thus the transformer for linear power supplies is often an inherent filter that reduces the amount of unwanted spectral content placed back on the product's power cord that is within the regulated frequency band for conducted emissions.

Another reason that linear power supplies are inherently clean is that they are typically not a strong source of high frequency signals themselves. Although the rectifier section and the regulating transistor can switch states to perform properly, the linear power supply itself generates much less high spectral content than other popular power supplies.

While linear power supplies are generally "cleaner" than other types of power supplies, they have become increasingly undesirable for two primary reasons. First, the transformer core that is used at the 60 Hz power frequency is typically very large and heavy. Newer types of power supplies are much lighter because they do not have these large transformer cores. Second, linear power supplies are not very efficient. A lot of power is dumped into the regulating transistor while the transistor tries to stabilize the output voltage under different loads. Typical efficiencies for linear power supplies are around 20% to 40% (Paul, 477). Newer types of power supplies, such as the switching power supply that will be studied in the next section, are much more efficient in converting AC line voltages into DC sources.

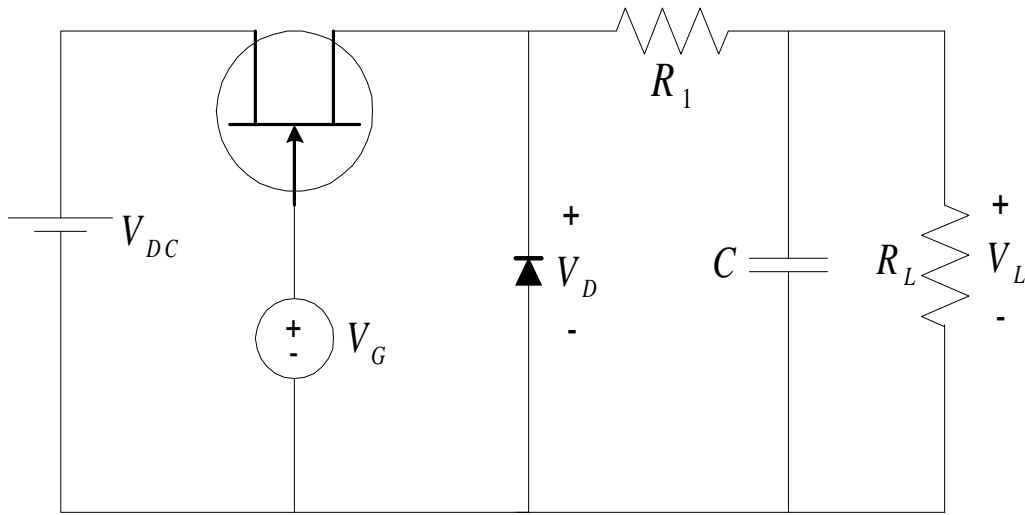

**Figure 17:** Illustration of AC signal and rectified (pulsating DC) signal.

### 11.5.2 Switched-Mode Power Supplies

As mentioned in the previous subsection, linear power supplies are both bulky and inefficient. A different type of power supply, the switched-mode power supply, is both more efficient (60% to 90% efficiency vs. 20% to 40% for linear supplies) and lighter in weight than a typical linear power supply. To boost the efficiency in linear power supplies, a lot of transformer core is used to prevent losses due to eddy currents at 60 Hz (Paul, 477). A switched-mode power supply, or “switcher”, uses transformers that need to operate at its switching frequency, which is typically somewhere between 20 kHz and 100 kHz. Losses due to eddy currents are not as large at these frequencies, thus the transformer cores for switching power supplies are smaller and lighter weight than their linear power supply counterparts.

There are many different kinds of specific switching power supplies, but we will study only

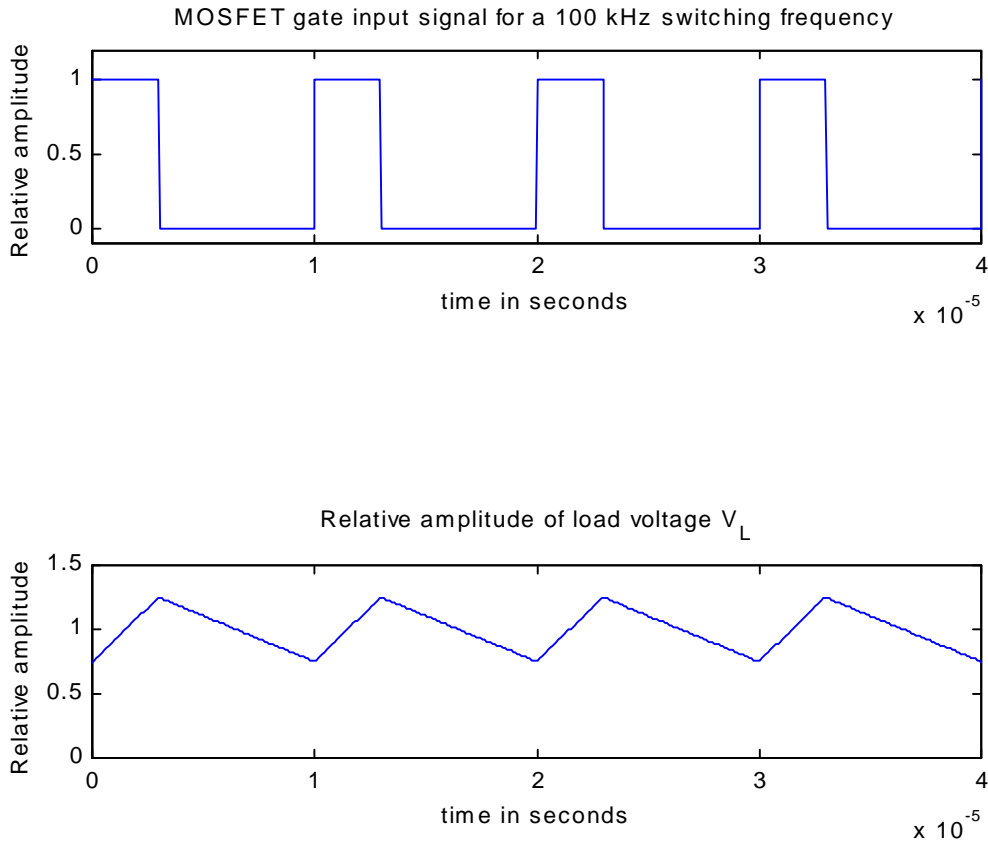

**Figure 18:** Schematic diagram of a buck regulator.

the simple concepts behind the operation of common supplies. To begin understanding how a switcher works, examine the circuit shown in **Figure 4**. A DC voltage  $V_{DC}$  is modulated by the voltage signal at the gate of the MOSFET,  $V_G$ . The signal  $V_G$  is a square wave operating at a period  $T$  and duty cycle  $\tau/T$ . **Figure 5** shows the shape of the signal  $V_G$  where the switching frequency is 100 kHz and the duty cycle is 30%. Thus the voltage  $V_D$  has the same shape as the signal  $V_G$  but has an amplitude of  $V_{DC}$ . By varying the duty cycle of  $V_G$ , the average value of  $V_D$  varies between 0 volts for a duty cycle of 0% and  $V_{DC}$  for a duty cycle of 100%.

When the MOSFET is turned on, (when  $V_G$  is at its peak), the diode is reversed biased and the capacitor begins to charge. When  $V_G$  falls to 0 volts, the MOSFET turns off, the diode becomes forward biased and conducts which begins to discharge the capacitor. If the capacitor value is chosen correctly, it will not completely discharge before the next period, when it resumes charging. The shape of the resulting voltage waveform at the load,  $V_L$  is shown in **Figure 5**. By varying the duty cycle of the MOSFET, the average or DC value of  $V_L$  can be controlled so that it maintains a constant level with various loads attached. The voltage  $V_L$  would normally be low pass filtered to remove the triangular oscillation about the average value.

The reason that the switcher is an efficient power supply is that little power is dissipated in the MOSFET while it is in the on or off state. The majority of the energy wasted in the MOSFET occurs during transition between high and low states. Contrast this with the linear power supply, where power can continuously be dissipated in the regulator transistor.

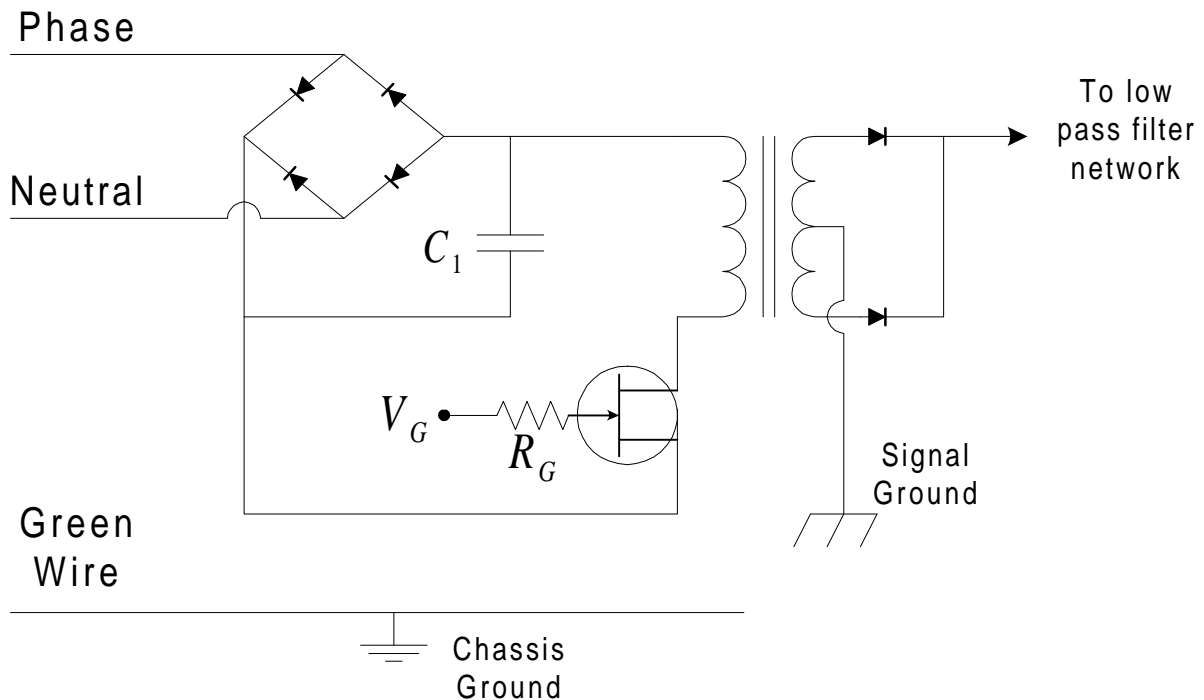

**Figure 19:** MOSFET gate voltage and resistive load voltages for the buck regulator circuit.

Now that the buck regulator circuit has been studied to understand the basics of a switcher, let us examine the simplified switching power supply shown in **Figure 6**. The four diodes at the phase and neutral power inputs to the supply act as a full wave rectifier to produce a pulsating DC waveform. The capacitor  $C_1$  helps hold the peak of the waveform. The MOSFET's gate input signal,  $V_G$ , is again a square waveform with a period  $T = 1/f$  where  $f$  is the switching frequency of the power supply. The signal  $V_G$  effectively opens or closes the connection between the primary side of the transformer and the capacitor  $C_1$ . At the output of the secondary of the transformer, a stepped-down version of the square wave signal appears with the average value removed. The transformer core thus needs only to operate at the switching frequency (20 kHz to 100 kHz) and above (for the harmonics due to the square signal) instead of at 60 Hz. The diodes on the secondary side of the transformer rectify the signal passed by the transformer, and a low pass filter network smooths the signal such that the power supply's output is close to DC. Regulation of the DC output voltage under different loading conditions is achieved by using a feedback signal to change the duty cycle of  $V_G$ .

The reason that switching power supplies are inherently larger contributors to conducted emissions than linear power supplies is due to the power MOSFET transitioning at the switching

frequency. The switching frequency and its harmonics are well within the frequency band



**Figure 20:** Schematic diagram of simple switching power supply.

regulated for conducted emissions. Electromagnetic energy at this frequency and its harmonics gets coupled back onto the AC power cord of the product. The type of switching power supply that was studied here is particularly prone to conducted emissions problems because the switching element is on the primary side of the transformer, where it creates interference that can couple almost directly to the power cord. Also, the MOSFET is switching a quasi-DC value of  $120 \cdot \sqrt{2} = 170$  volts. Thus the energy that is coupled to the power cord is much higher in amplitude than if the MOSFET was on the secondary side of a transformer, where it would be switching a stepped-down voltage. A good power supply filter is needed for any switching power supply to be able to pass a conducted emissions regulatory test.

## 11.6 Conducted Immunity

As mentioned in the overview of this module, conducted immunity refers to a product's resilience to electromagnetic interference coupled in through its AC power cord. However, in most cases, the amplitude of the signals that try to enter a product through its AC power cord are generally very small and are usually further reduced by the product's power supply and its power supply filter. Remember that the primary reason that conducted emissions are a problem is that electromagnetic energy finds its way to the power distribution network (a house, a building, etc.) where it is radiated and received by another product.

Conducted immunity problems are primarily due to large variations or transients on the power distribution network where the product receives its power. Lightning, electromagnetic pulses (EMP) and power surges are examples of types of electromagnetic interference that can couple to a product directly through its AC power cord. A well designed power supply and power supply filter will help a product increase its resilience to some of these phenomena. However, some phenomena such as an EMP from a nuclear bomb explosion are sporadic enough that designing household devices to operate while withstanding possible interference from EMPs is not important. The military is very interested in their equipment working after a nuclear blast. EMPs create large problems for both radiated immunity and conducted immunity.

One market in which conducted immunity is heavily tested is in the automotive industry. In an automobile, electromagnetic interference can couple into (or out of, in the case of conducted emissions) an electronic module from its DC power lines, bus lines, and sensor lines. The automobile industry tests their modules for their conducted immunity by injecting current over a large frequency range on each input line to the module. This occurs as the module is turned on and placed in conditions close to where it would normally operate. If the module demonstrates that it has problems operating properly with an injected current at a certain frequency, the module is examined to see what can be changed such that it can operate properly if a current would naturally enter the module under driving conditions.